

D Tuner / Modulator

Im Reparaturfall ist der Tuner/Modulator - aus Gründen des umfangreichen Abgleichs - in einer der Servicestellen zu tauschen.
Servicearbeiten nach Bausteinwechsel: Abgleich Nr. 2 und 3 des ZF-Verstärkers

Hinweis: Sollten Störungen (Moiré, Schlangenlinien) am FFS-Bildschirm auftreten, so können Sie die Frequenz des Modulators zwischen K 30 und K 40 variieren und somit die Störungen beseitigen.

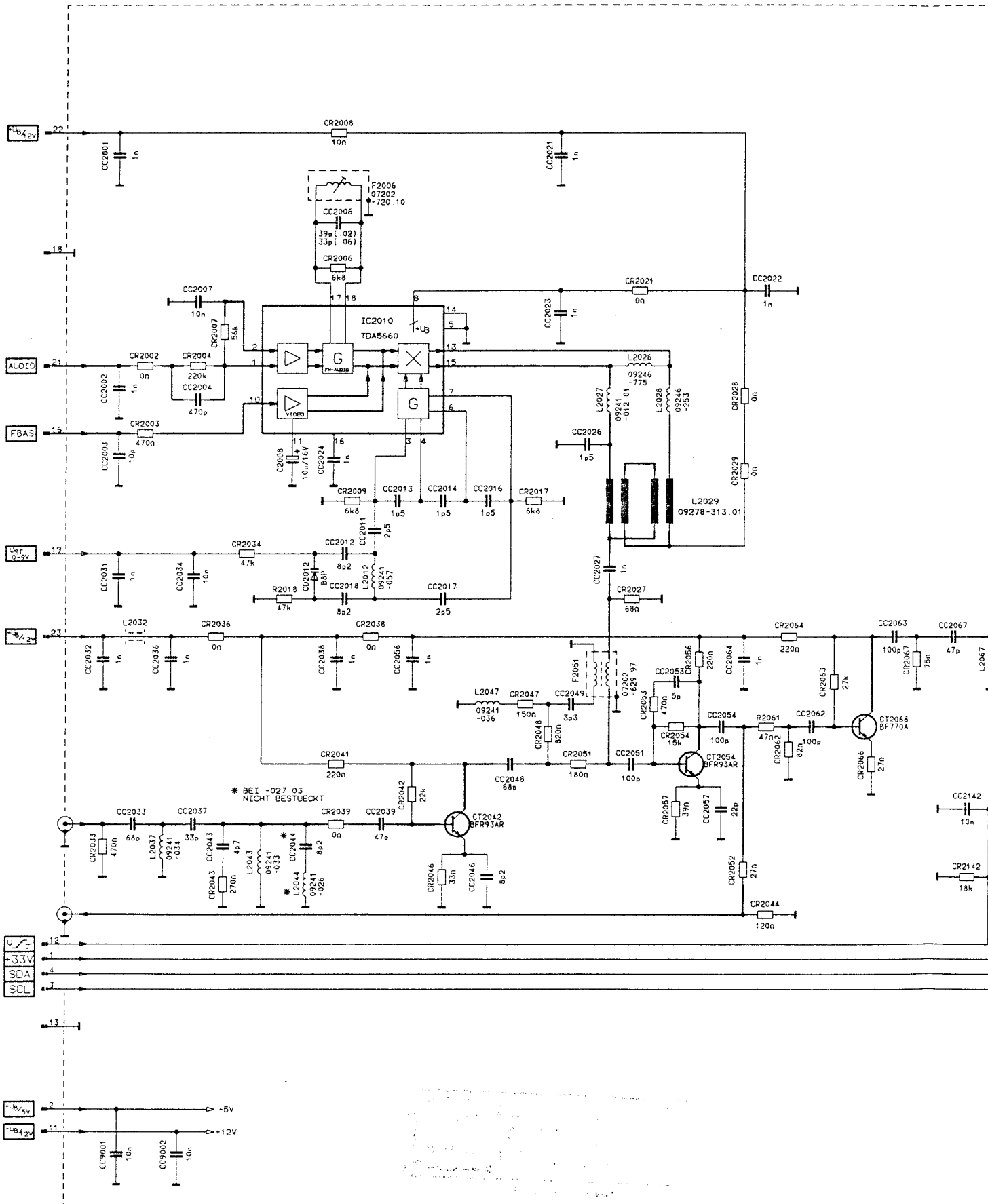

(GB) Tuner / Modulator

der Servicestellen zu tauschen.

die Frequenz des Modulators zwischen K

For reasons of the extensive alignment procedure, it is recommended to return a defective Tuner/Modulator to the Seller or to replace it by a new one.

Servicing work after changing board: Alignment no. 2 and 3 of the IF Amplifier

Note: Should interference (Moire, waving lines) appear onto the screen of the CTV the frequency of the modulator should be adjusted on CH 30 and CH 40 so that interference is avoided.

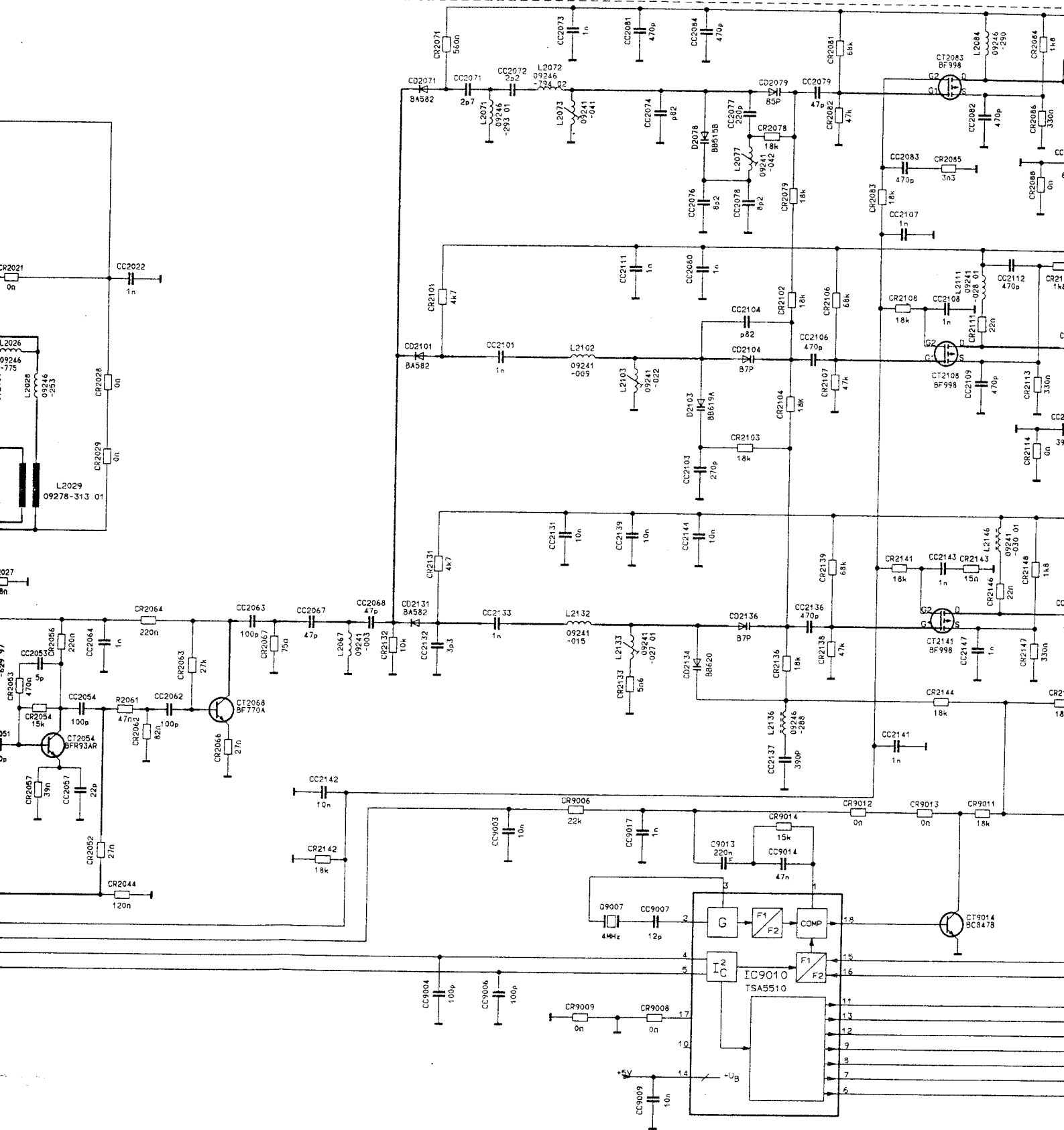

commended to return a defective Tuner/Modulator to the Service Organization to get

and 3 of the IF Amplifier

onto the screen of the CTV the frequency of the modulator can be adjusted between

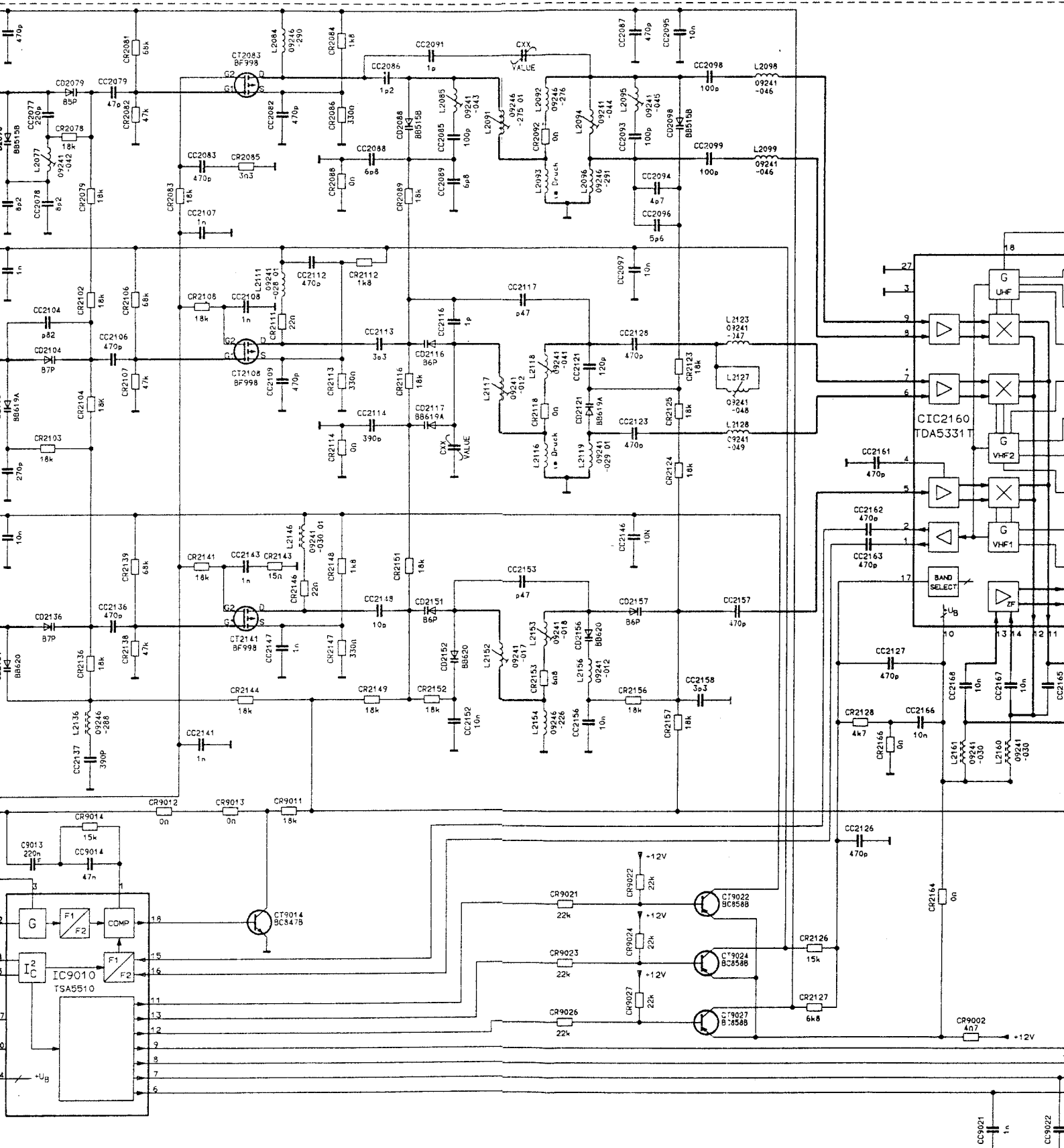

ion to get

between

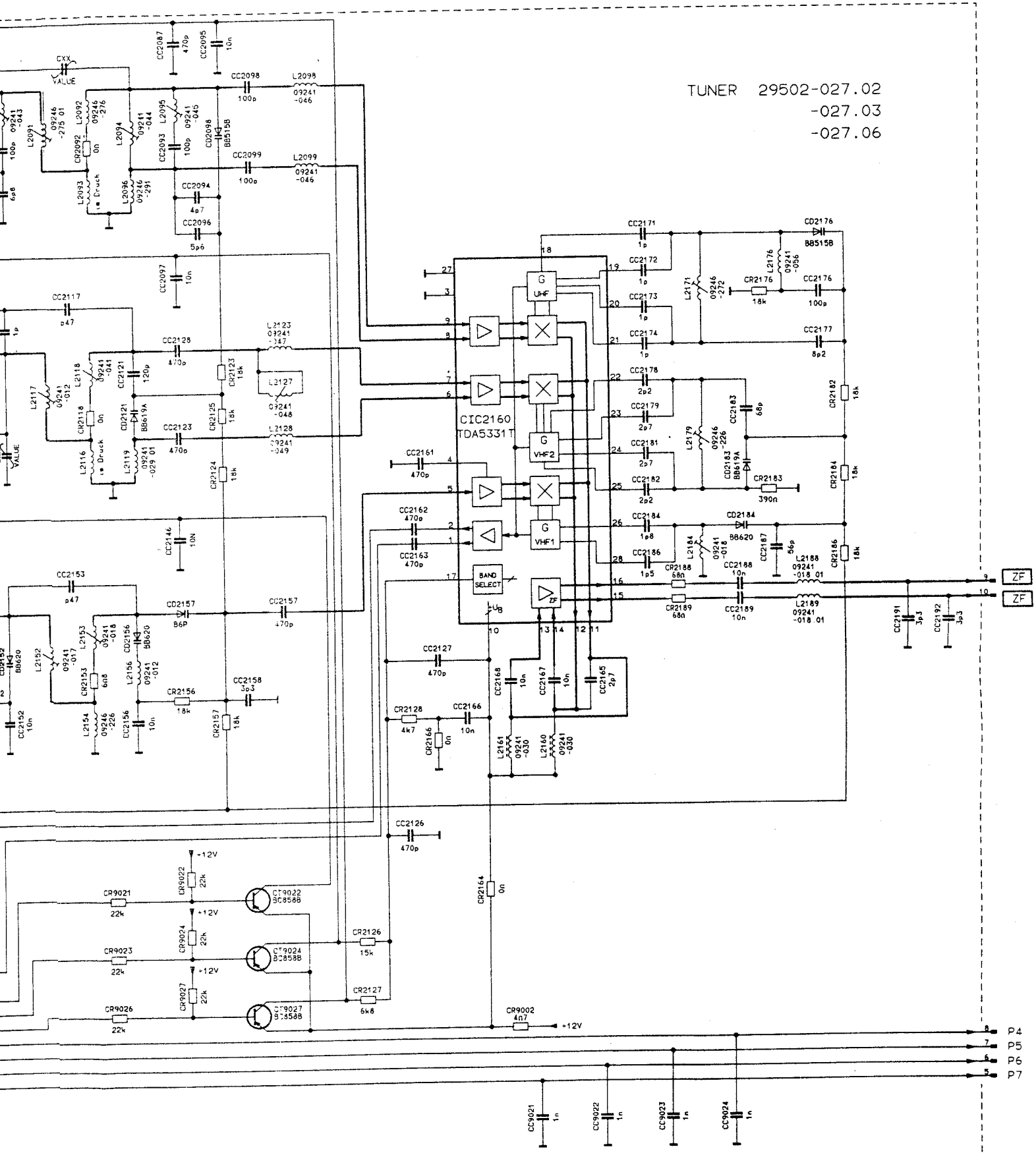

TUNER 29502-027.02
 -027.03
 -027.06

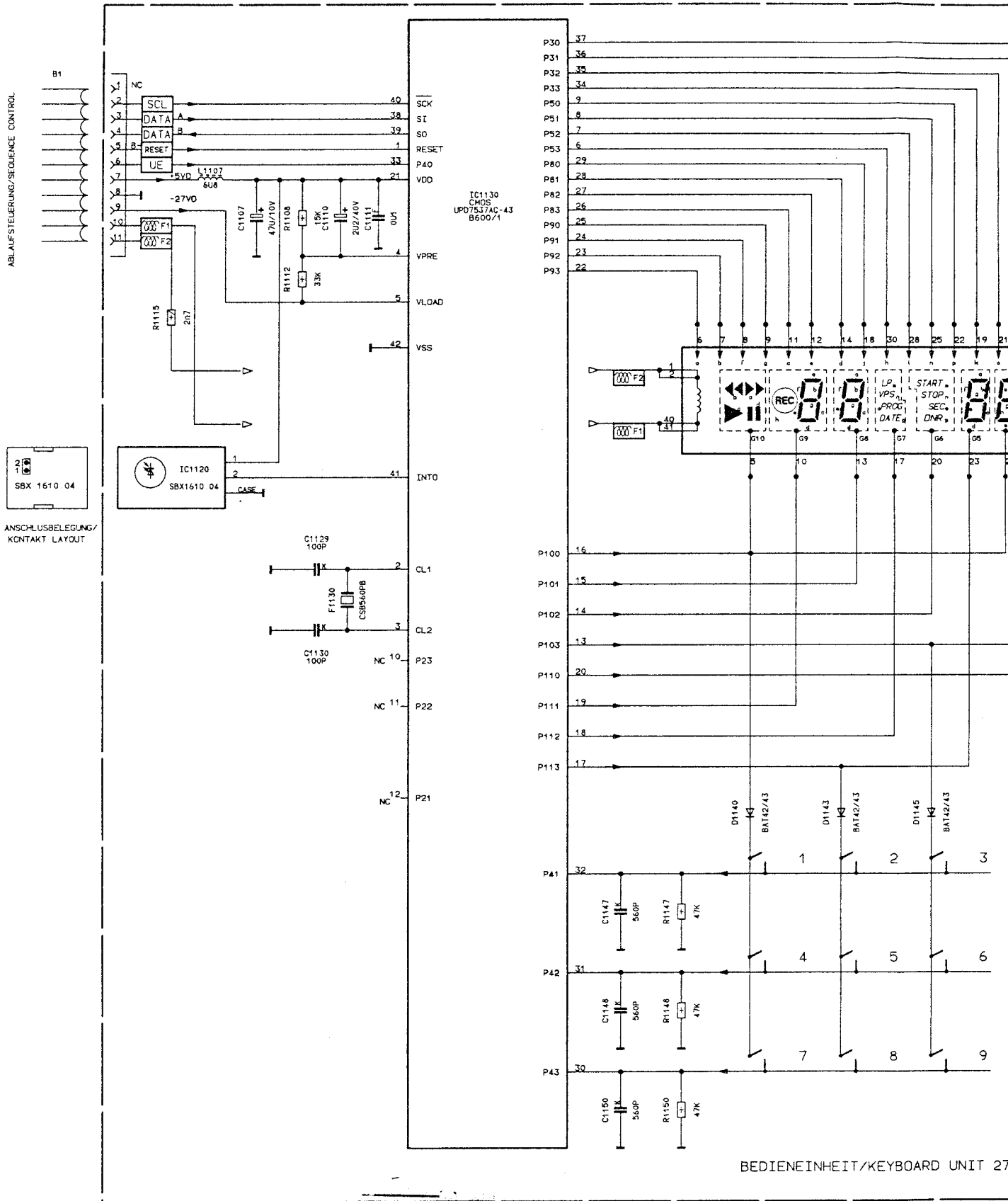

**Bedieneinheit
Keyboard unit**

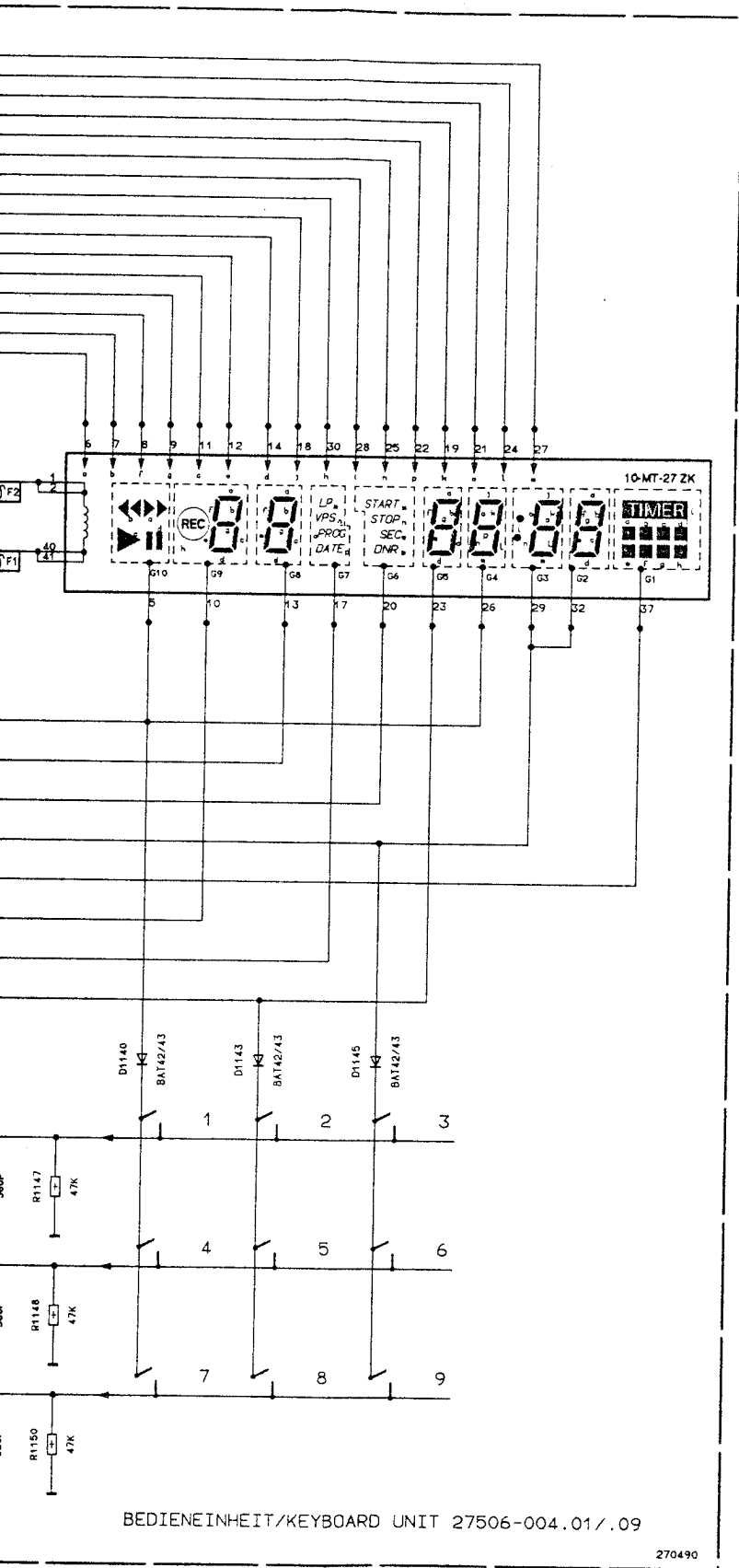

Taste / Key	
1	
2	
3	
4	
5	
6	
7	
8	
9	

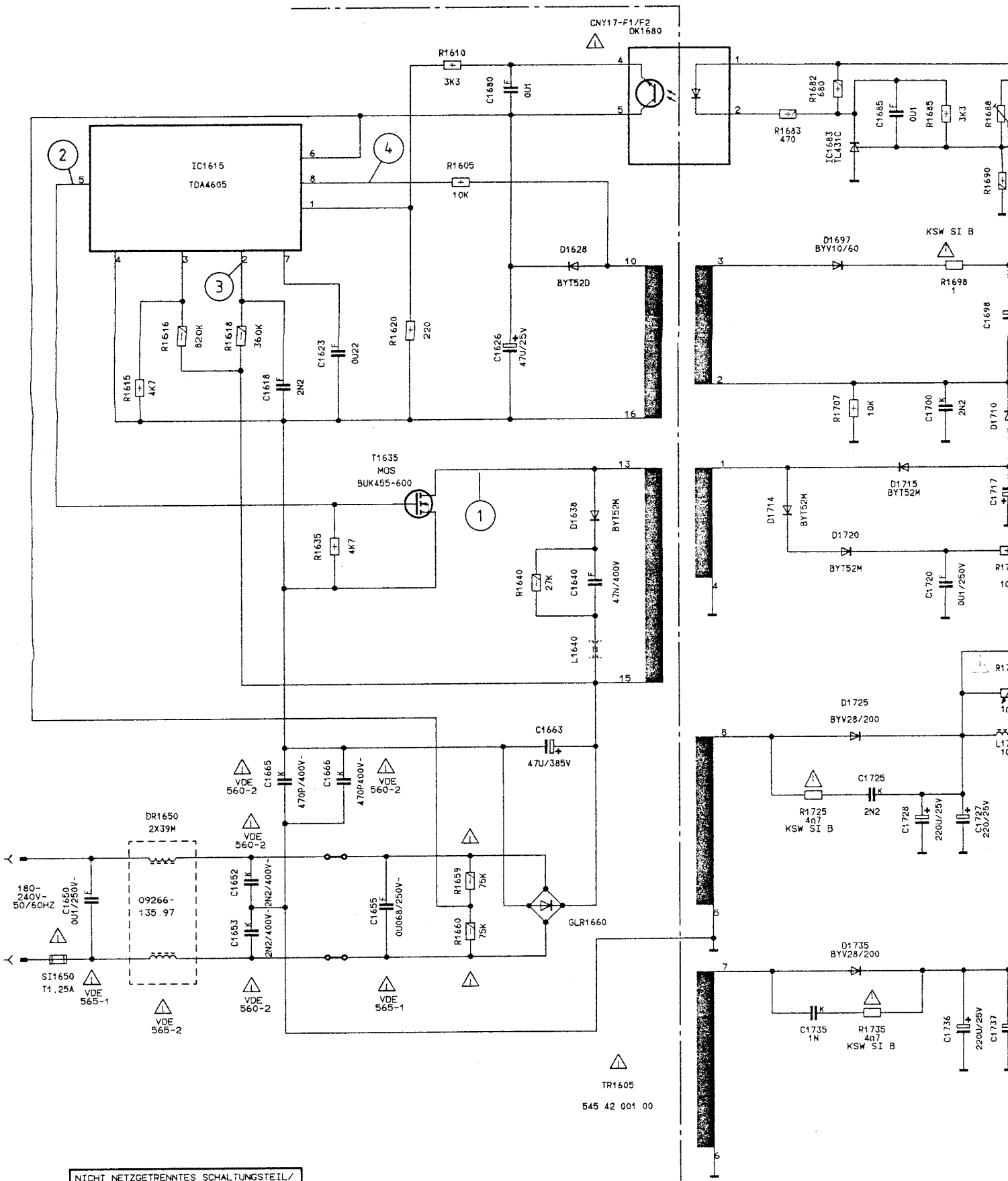

NICHT NETZGETRENNTES SCHALTUNGSTEIL/
CIRCUIT NOT MAINS-ISOLATED

NETZTEIL/MAINS UN

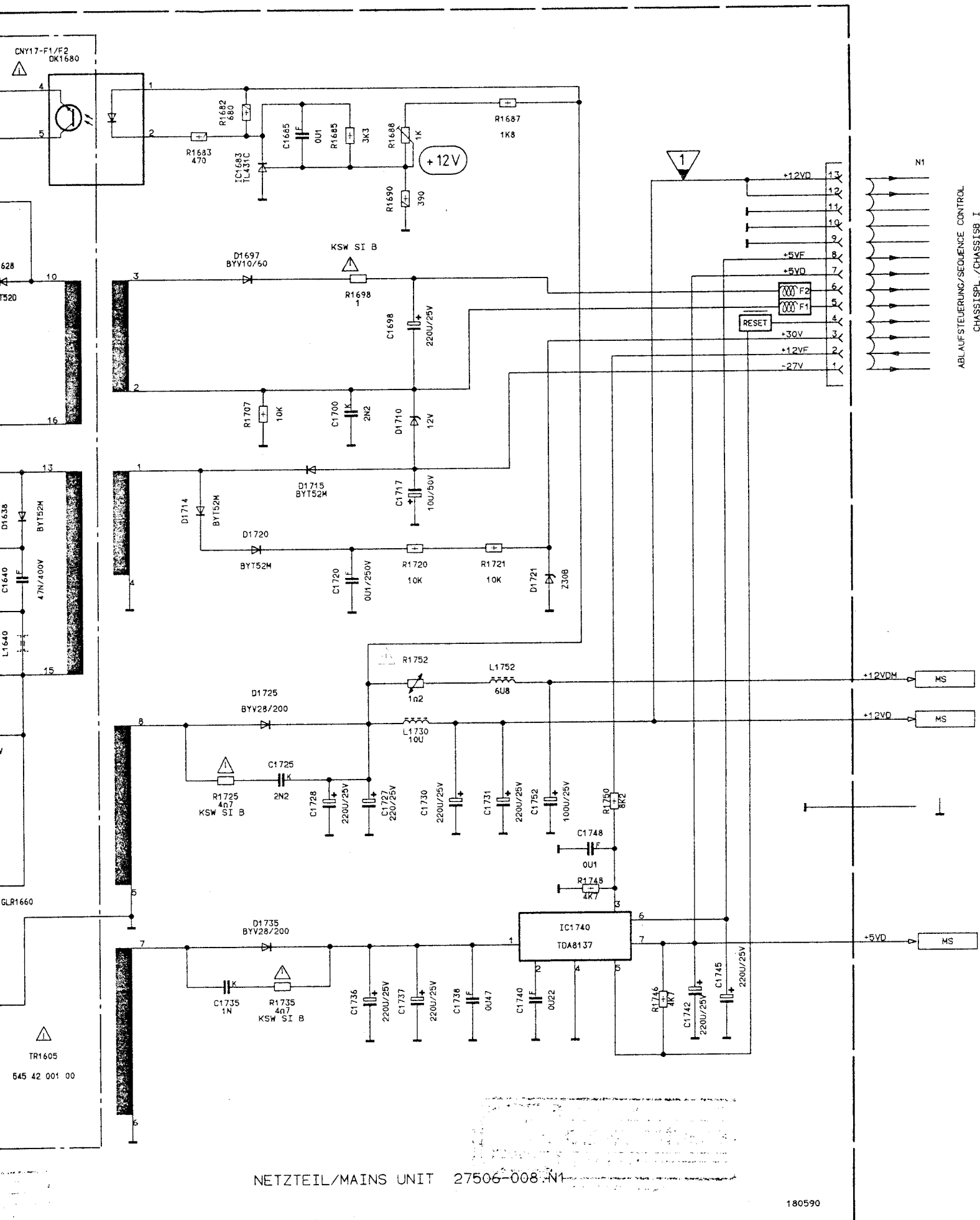

NETZTEIL/MAINS UNIT 27506-008-N1

180590

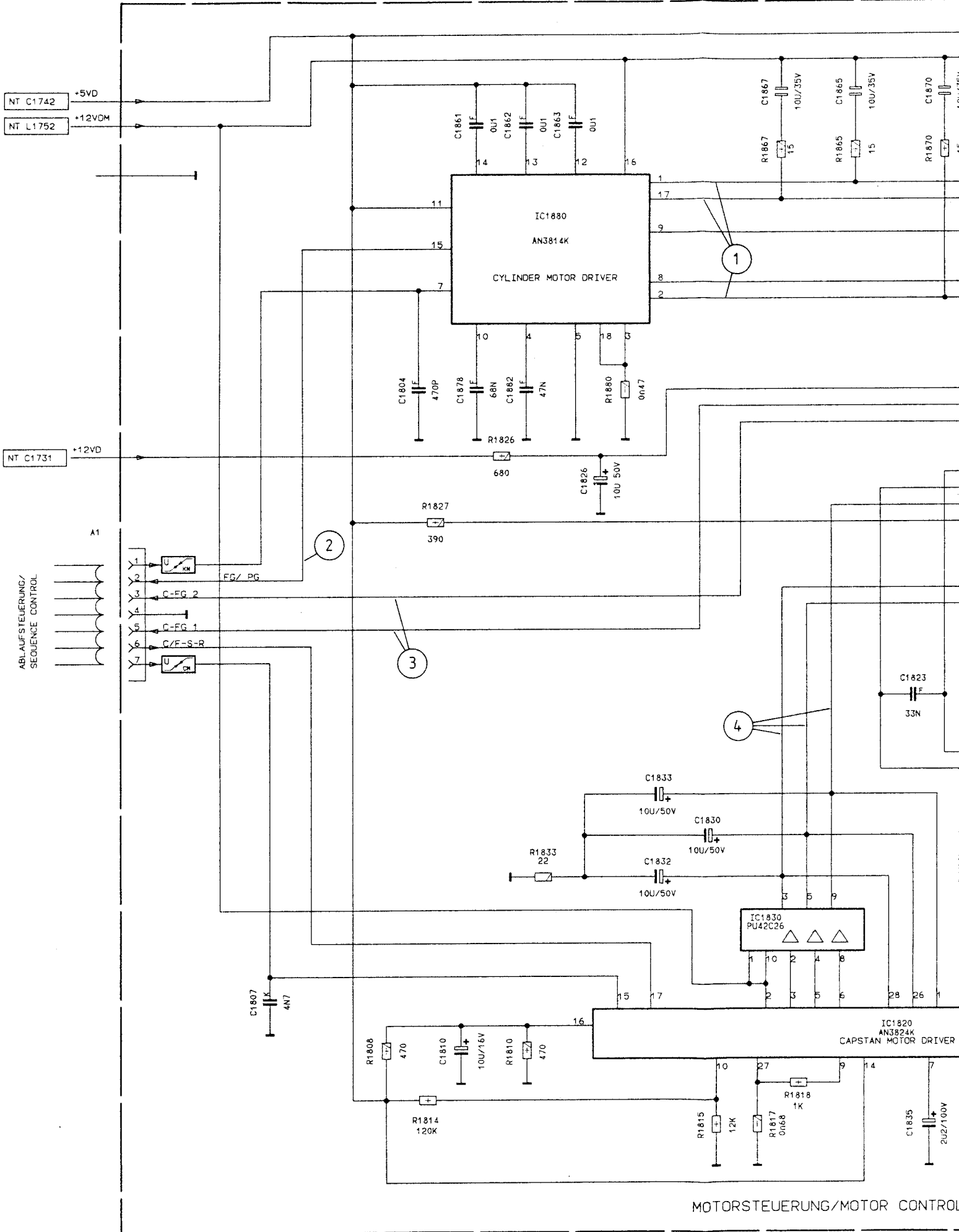

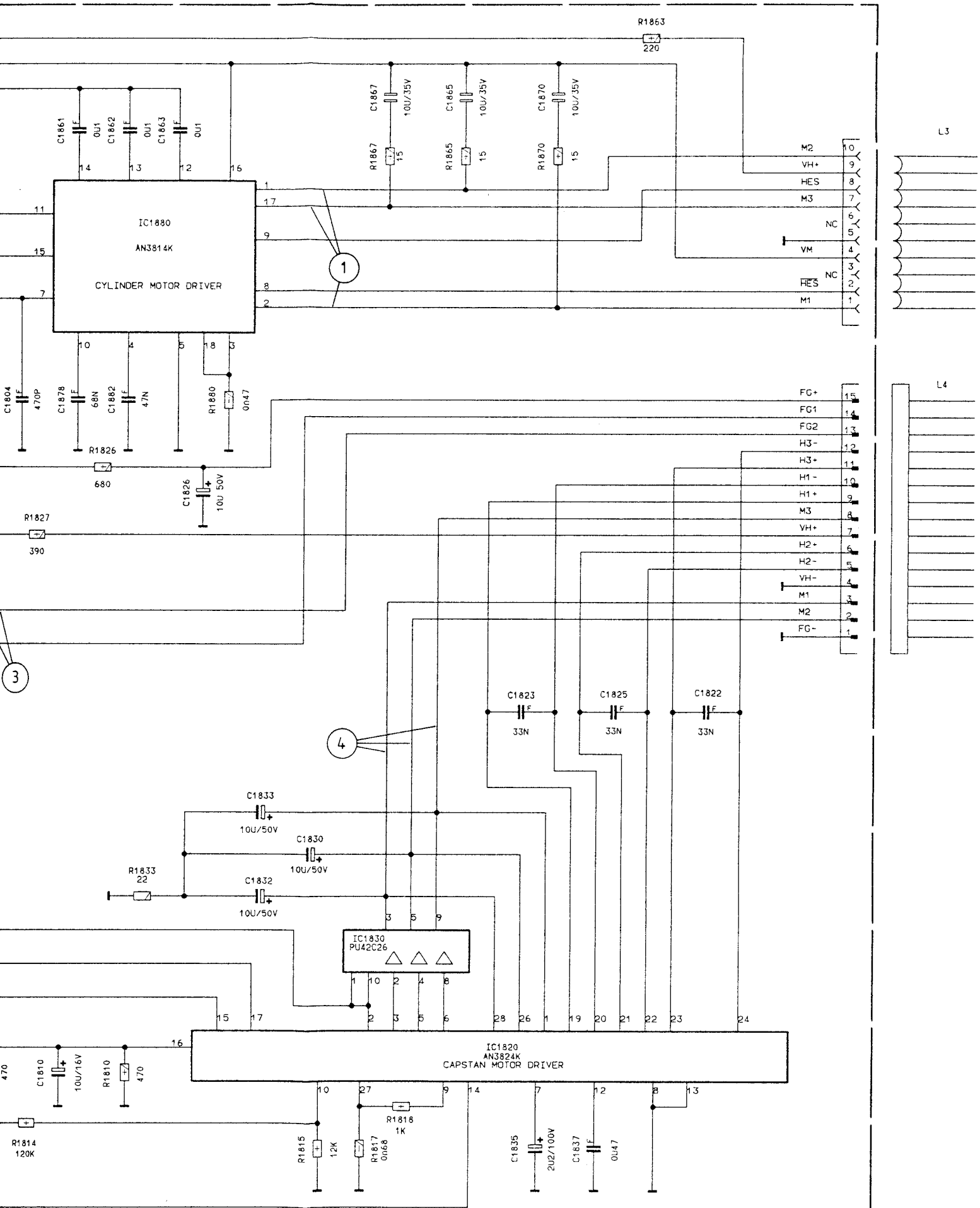

MOTORSTEUERUNG/MOTOR CONTROL 27506-008.M1

030590

RTV servis Horvat

Tel: ++385-31-856-637

Tel/fax: ++385-31-856-139

Mob: 098-788-319

www.rtv-horvat-dj.hr

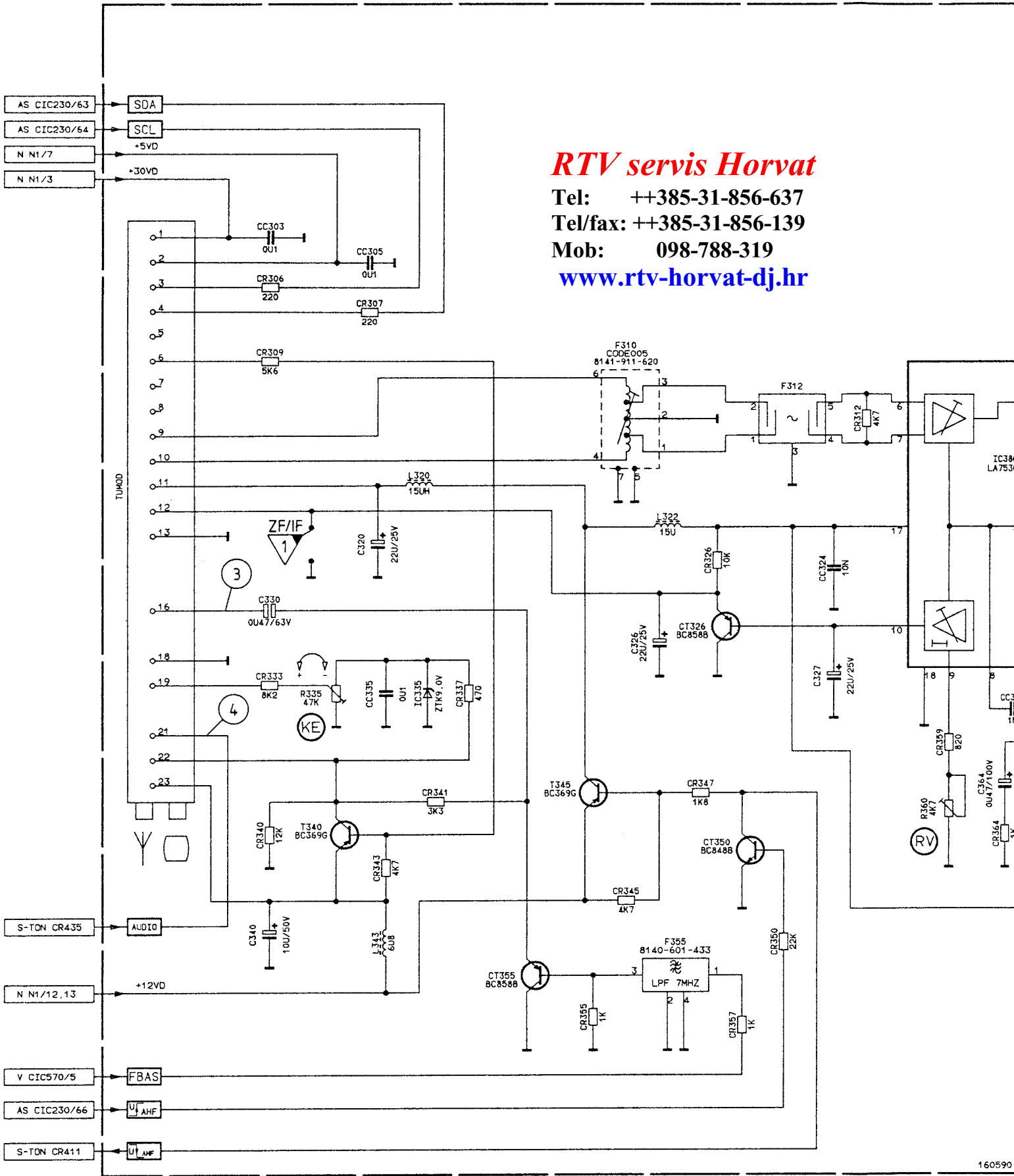

	F 380	F 385	F 312	CC 370	F 370	TUMOD	CC380	L380
.F1	SEF 5.5 MC	TPS 5.5 MW	OFW G1962	18P	CDA 5.5MC	29502-027.02	47P	12U
.63 (GB)	SEF 6.0 MB	TPS 6.0 MD	OFW J1952	10P	CDA 6.0MC	29502-027.06	47P	12U

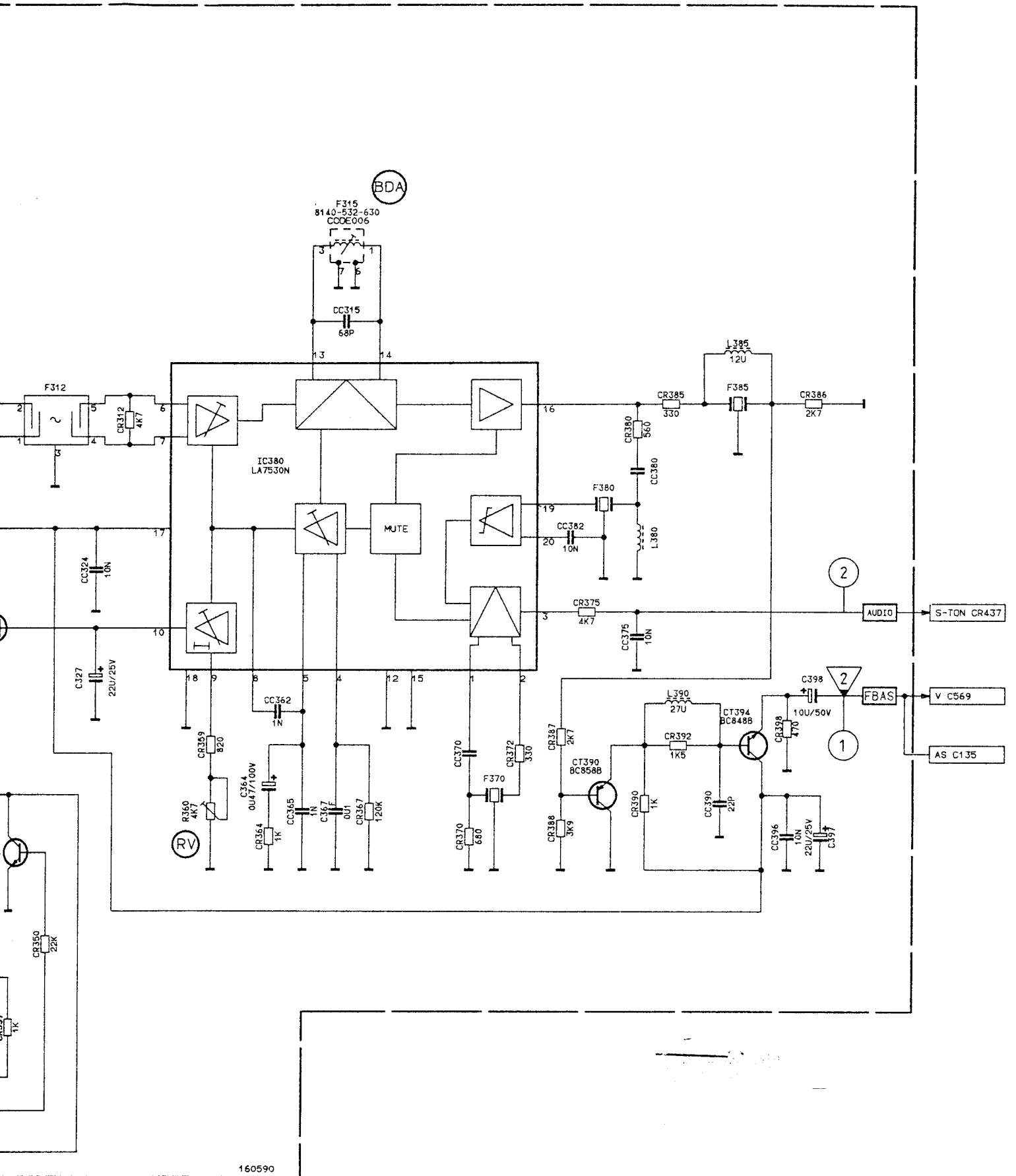

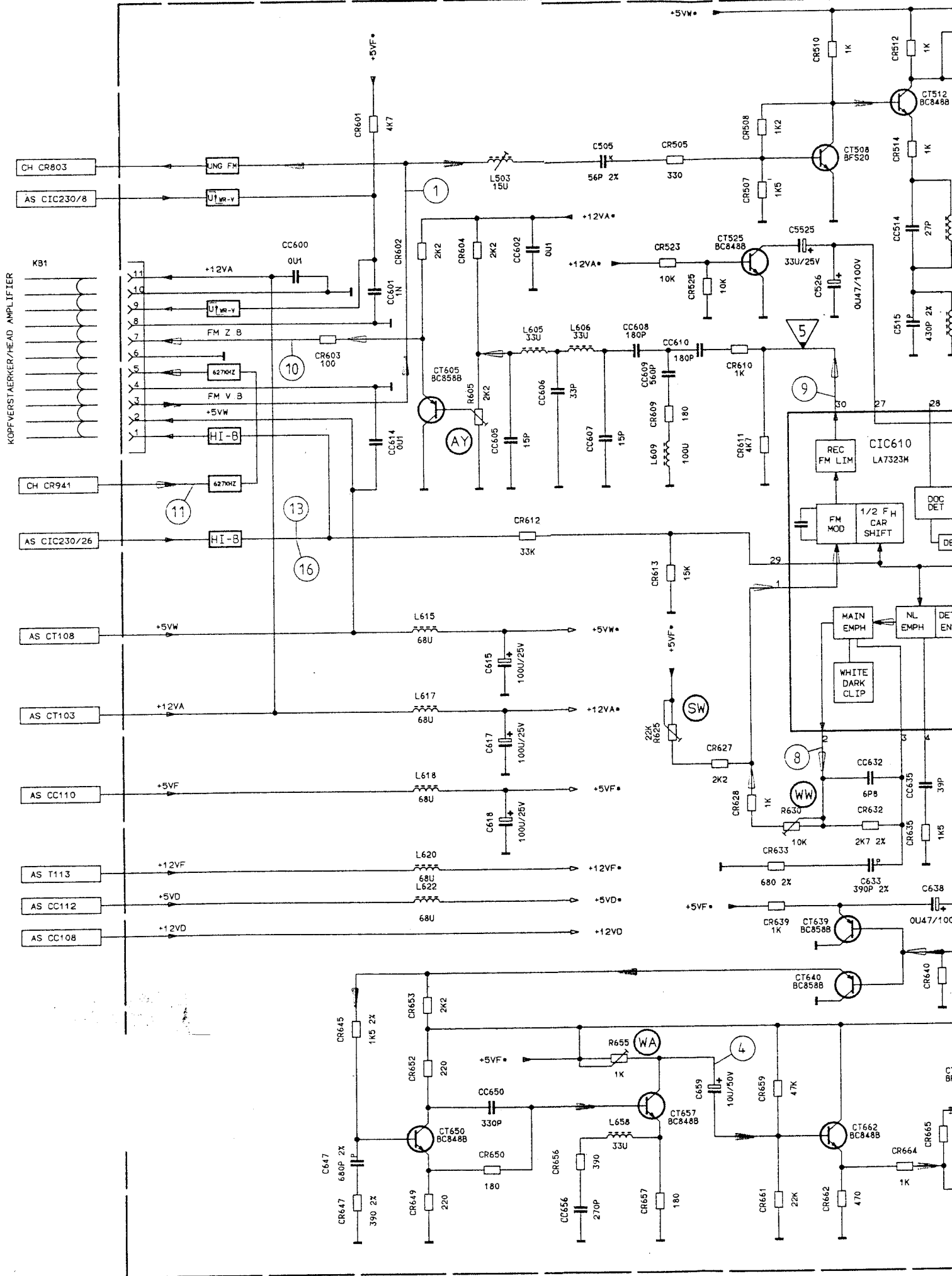

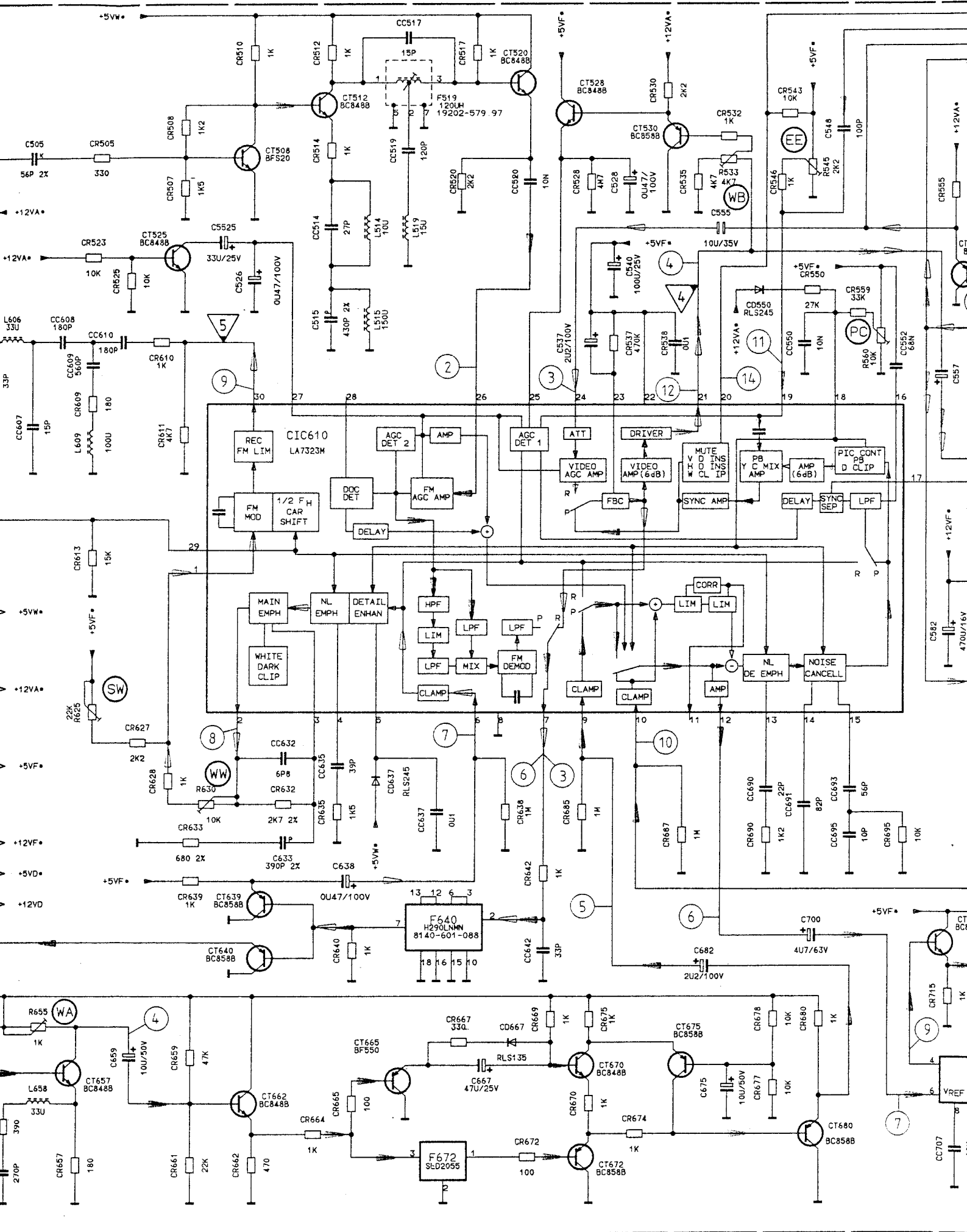

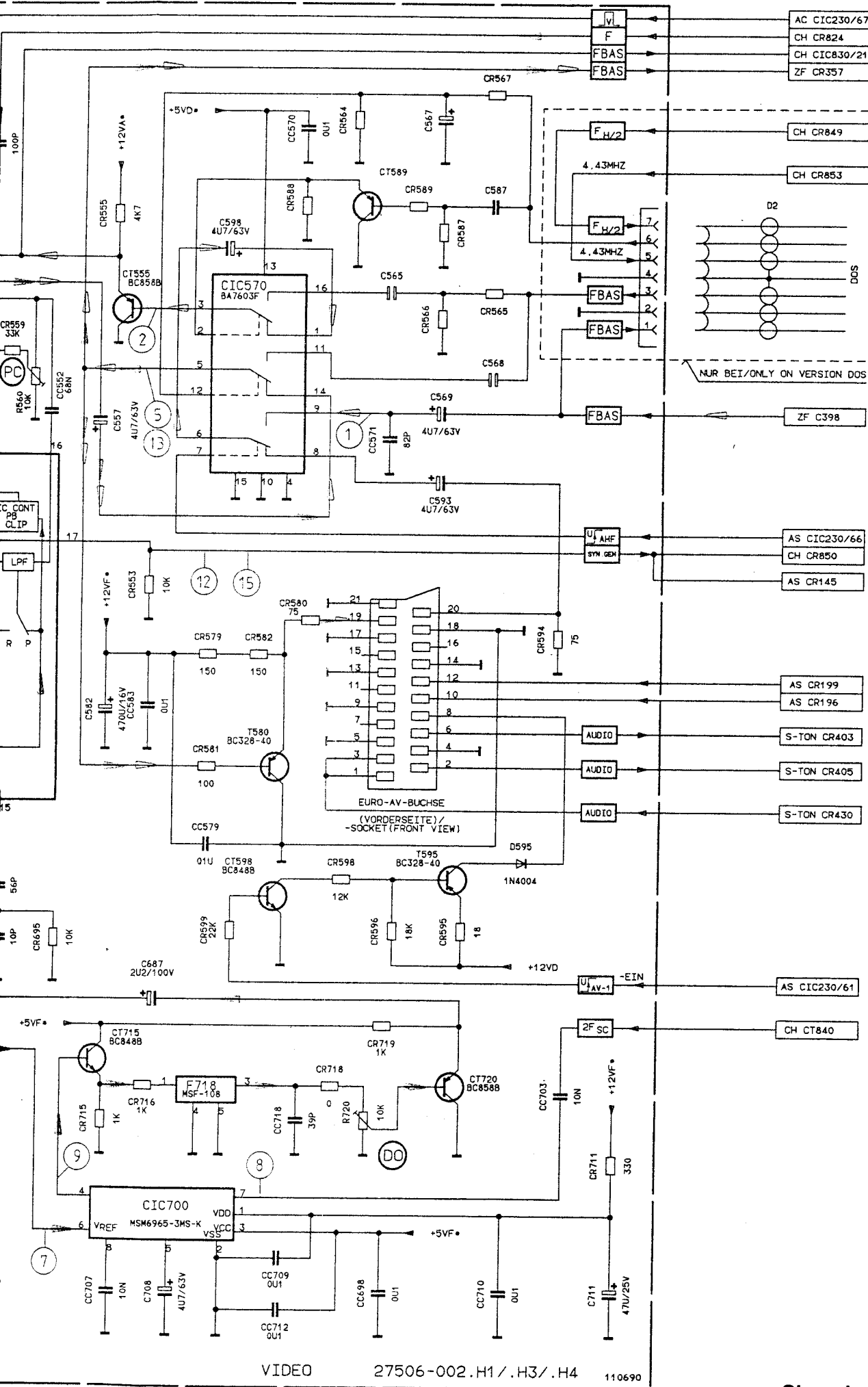

27506-002.H1

CR587	-
CR589	-
CT589	-
C587	-
C565	-
CR566	-
CR565	-
CR588	0Ω
C568	-
CR564	1kΩ
C567	-
CR567	-

VIDEO 27506-002.H1/.H3/.H4 110690

Chassisplatte – Video
Chassis board – Video

Aufnahme
Record

Wiedergabe (PAL)
Playback (PAL)

Wiedergabe (SECAM)
Playback (SECAM)

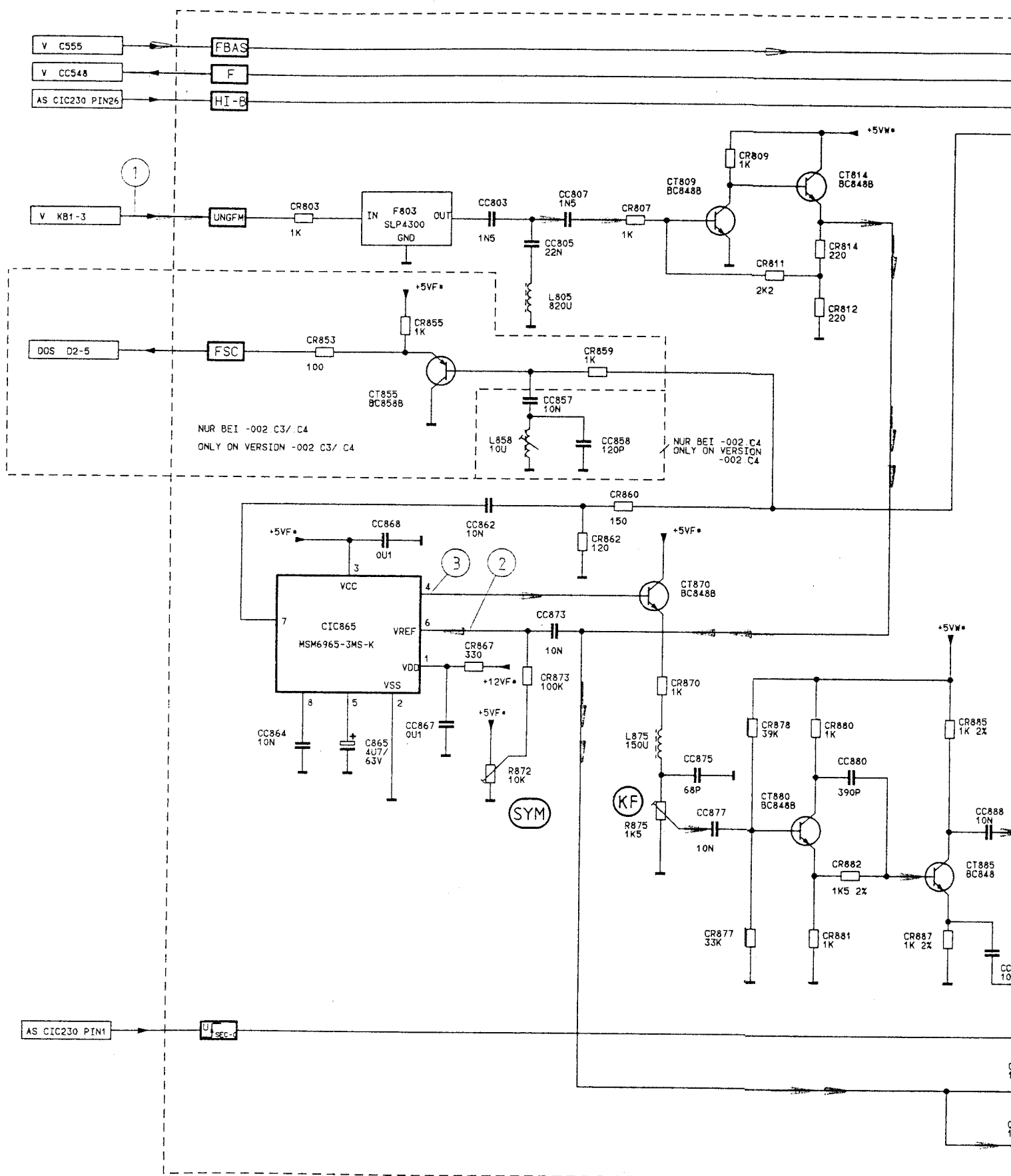

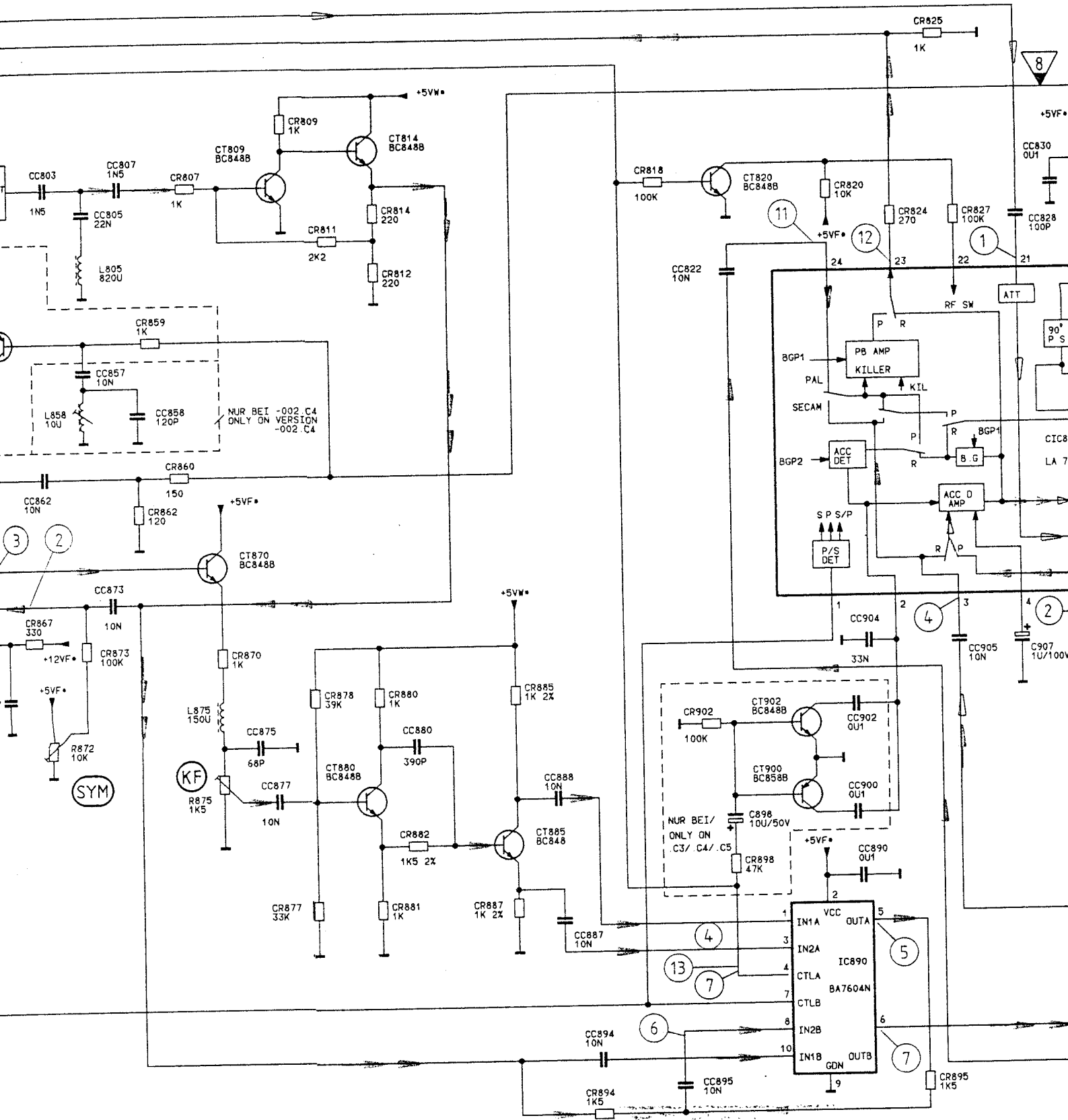

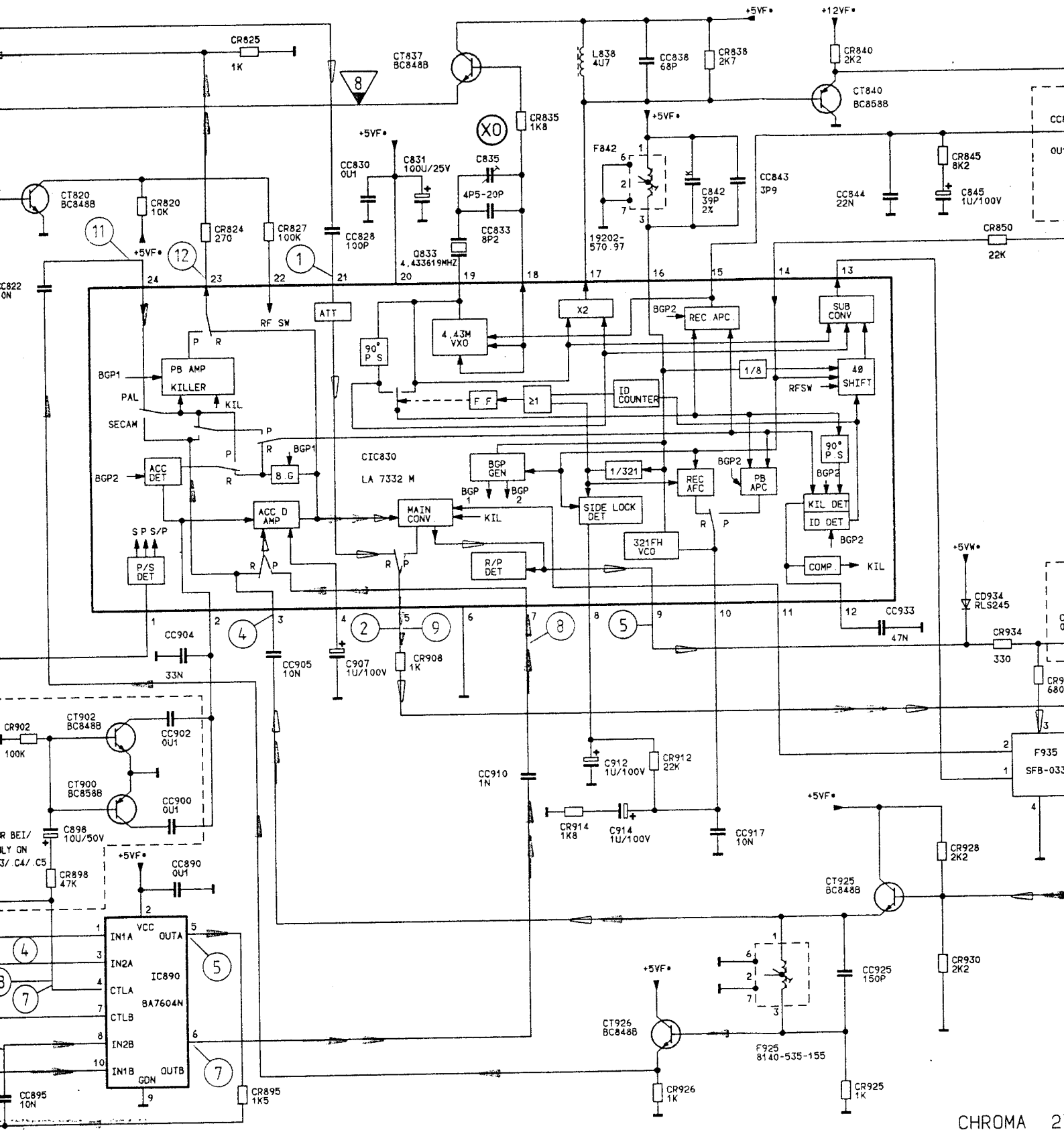

CHROMA 2

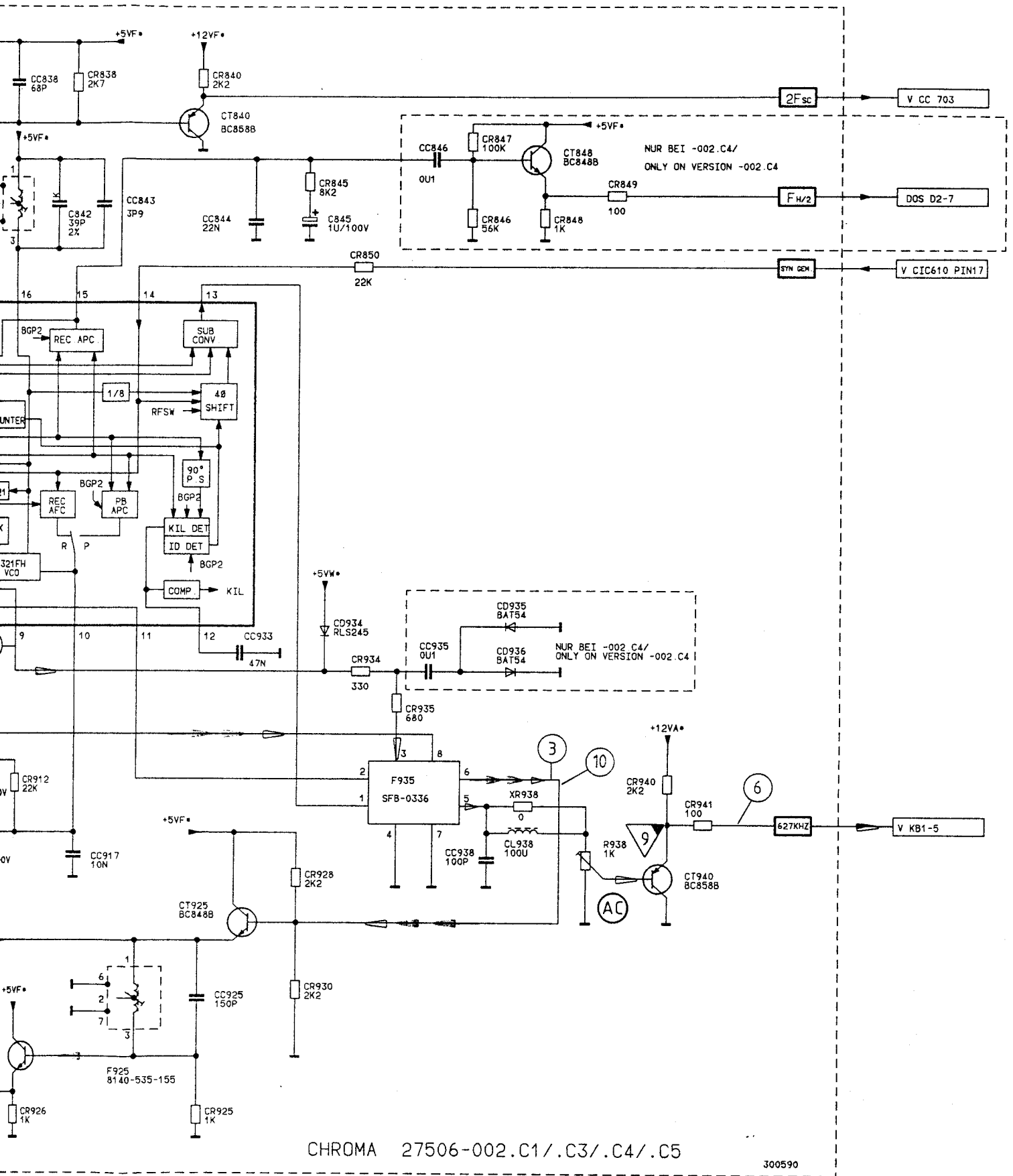

Chassisplatte – Chroma
Chassis board – Chroma

Aufnahme
Record
Wiedergabe
Playback

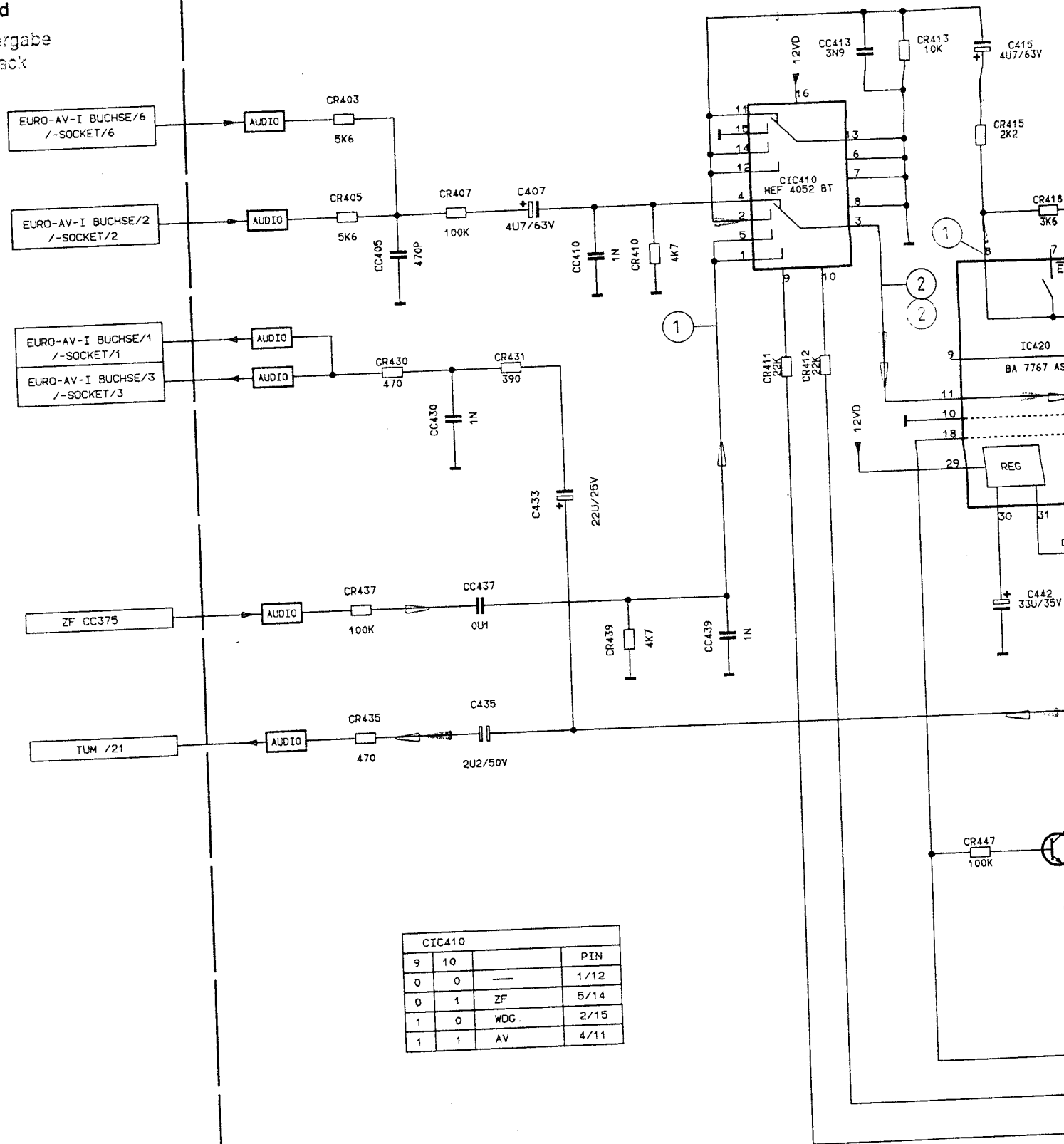

CIC410			
9	10		PIN
0	0	—	1/12
0	1	ZF	5/14
1	0	WDG.	2/15
1	1	AV	4/11

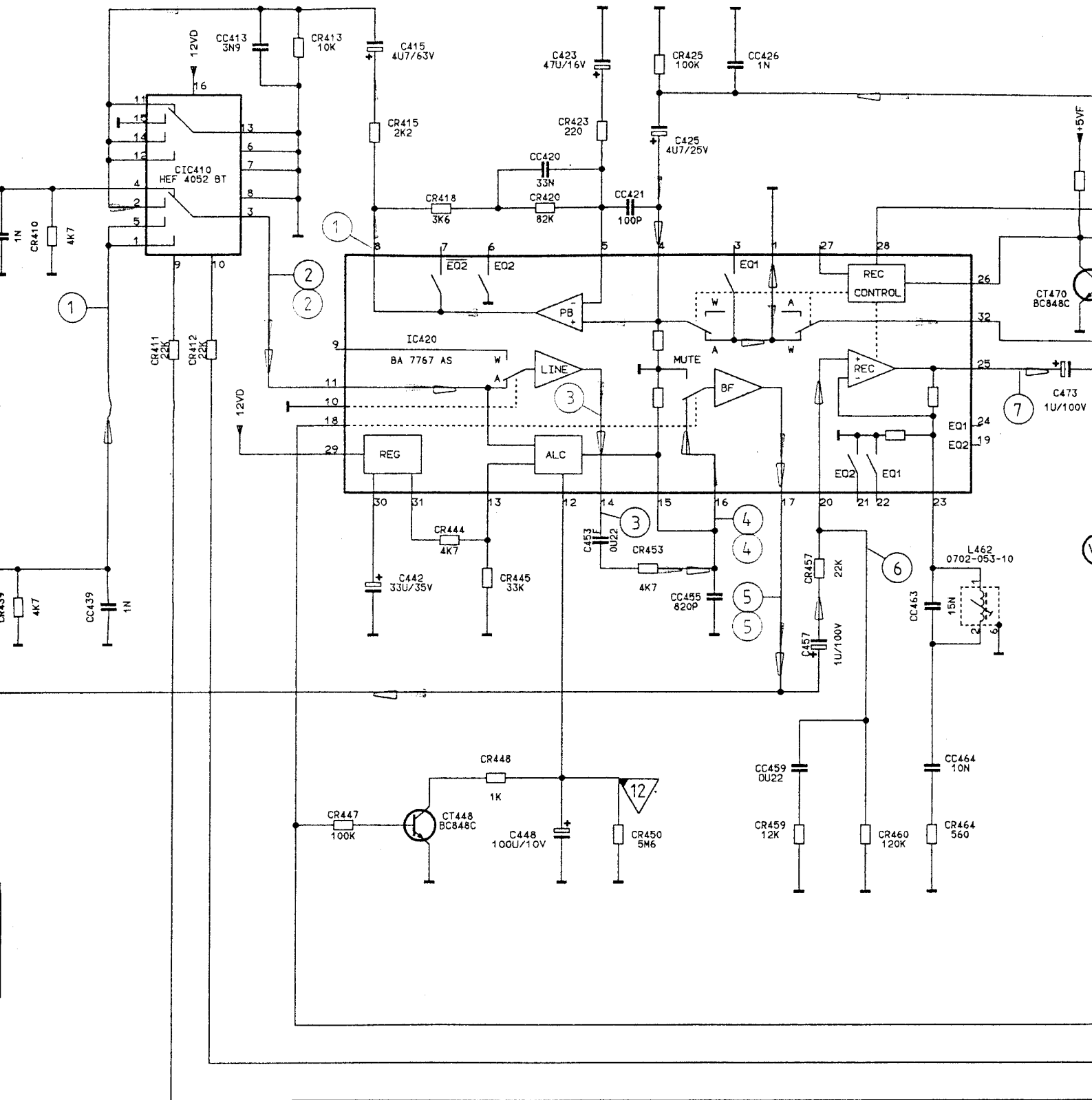

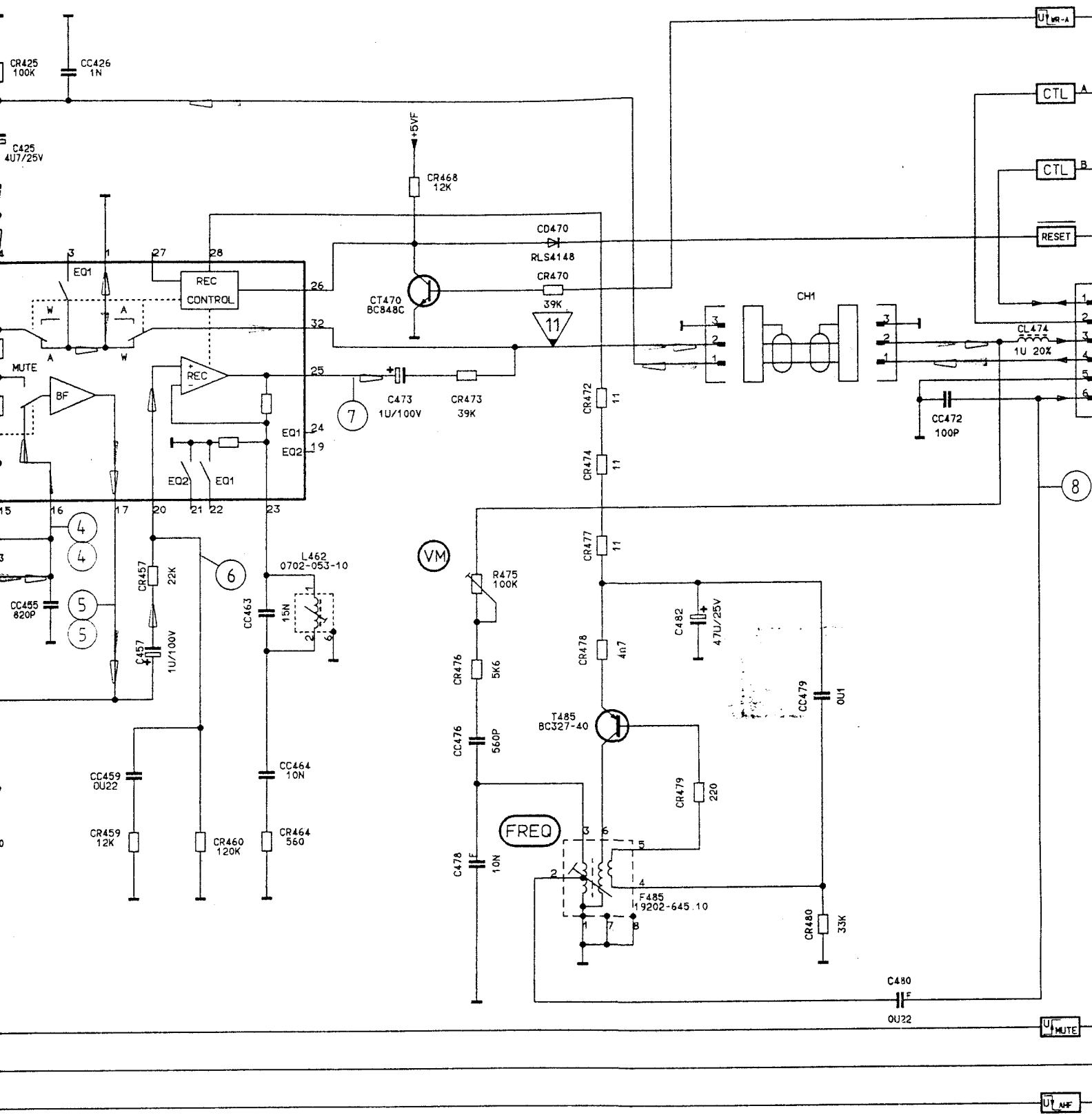

STANDARDTON/-SOUND 27506-002.M1

140590

Chassisplatte – Standard-Ton
 Chassis board – Standard Sound

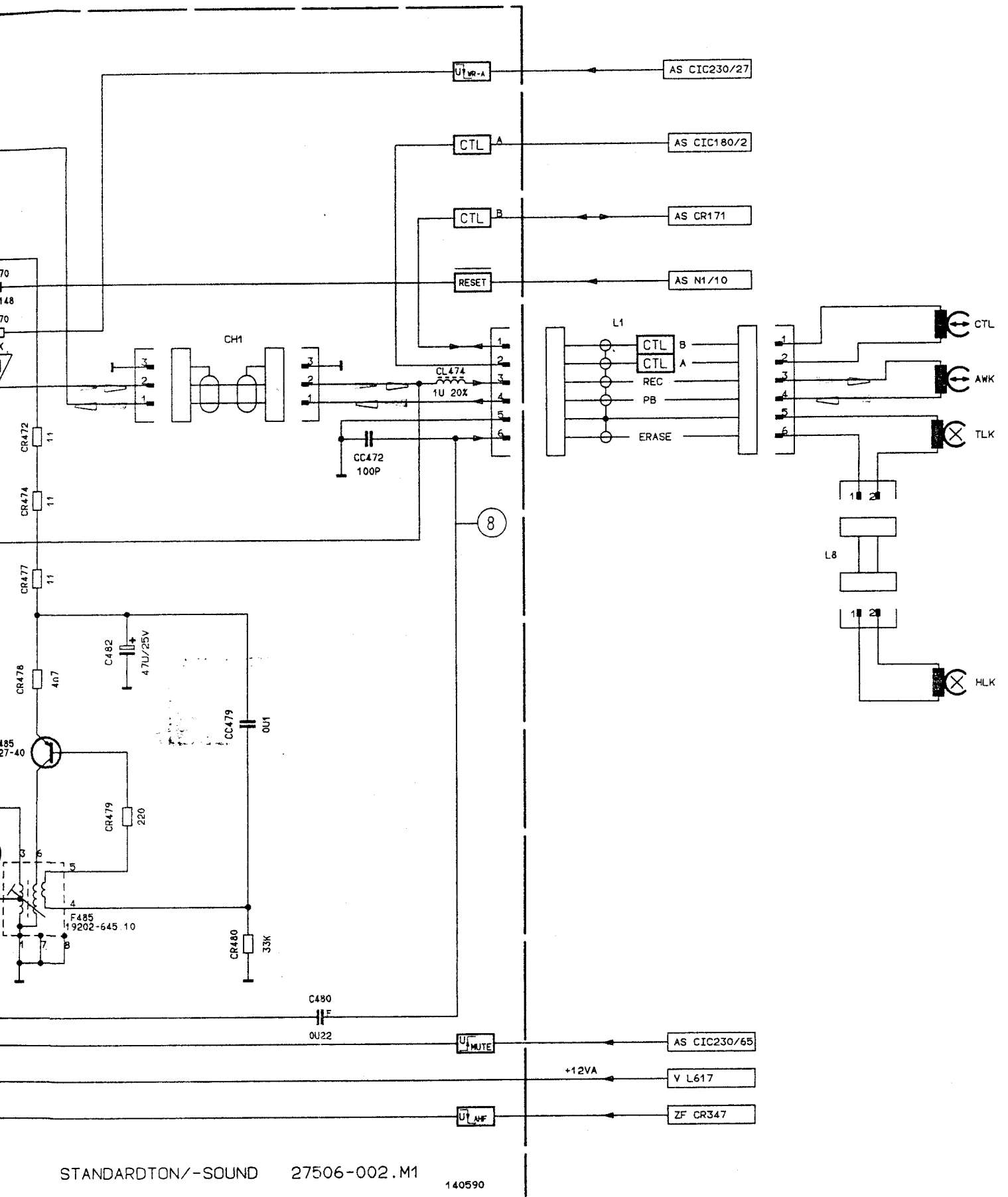

Chassisplatte – Standard-Ton
Chassis board – Standard Sound

Kopfverstärker Video head amplifier

Aufnahme
Record
Wiedergabe
Playback

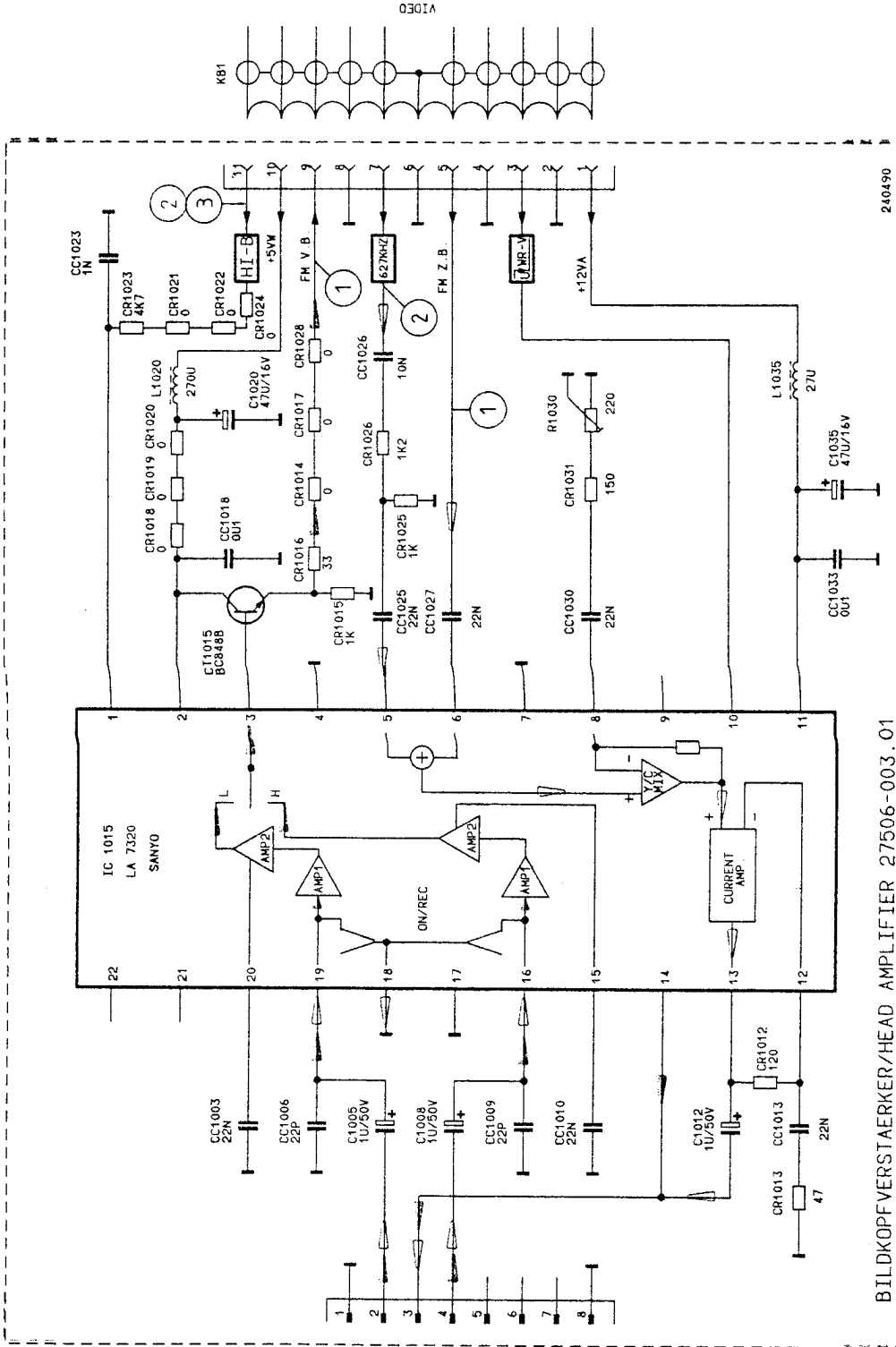

BILDKOPFVERSTÄRKER/HEAD AMPLIFIER 27506-003.01

